

**KIT PART NUMBER 6532035, 6532037, 6532040, & 6532042
INSTRUCTIONS FOR INSTALLING A BACKLIT DISPLAY KIT**

CHECK THE PARTS RECEIVED IN THE KIT WITH THE PARTS LIST IN THESE INSTRUCTIONS. IF ANY PARTS ARE MISSING, CONTACT THE CRANE MERCHANDISING SYSTEMS PARTS DEPARTMENT IMMEDIATELY.

Read these instructions carefully before installing the kit.
Keep these instructions for part numbers and for future reference.

KIT USAGE

KIT PART NUMBER	VOLTAGE, MODEL NUMBER, COLOR, AND COUNTRY
6532035	110V, 653, 655 & 657 BROWN P.O.P.-US
6532037	230V, 653, 655 & 657 BROWN P.O.P.-UK
6532040	230V, 653, 655 & 657 BROWN P.O.P.-GER
6532042	230V, 653, 655 & 657 BROWN P.O.P.-FR

THIS KIT CONTAINS THE FOLLOWING

PART NUMBER	DESCRIPTION	QTY PER KIT			
		6532035	6532037	6532040	6532042
6532034	KIT INSTR. FOR INSTLG. A BKLIT. DISPLAY	1	1	1	1
6532013	MOUNT ASSEMBLY, LOWER	1	1	1	1
6532016	BRACKET, LIGHT TUBE	1	1	1	1
6532017	INSULATION DISC	1	1	1	1
6532025	FRAME, DISPLAY, P.O.P.	1	1	1	1
6532018	RETAINER, DISPLAY	1	1	1	1
6532024	P.O.P. BACKLIT, HDC, BROWN	1	1	1	1
6532032	RETAINER, TOP, P.O.P.	1	1	1	1
6532033	RETAINER, BOTTOM, P.O.P.	1	1	1	1
P6532019	BALLAST ASSEMBLY	1			
P6532030	BALLAST ASSEMBLY, FOREIGN		1	1	1
P6532020	BACKLIGHT ASSEMBLY	1	1	1	1
6532060	BRACKET, BALLAST MOUNTING		1	1	1
6539002	HARNESS, BACKLIGHT, HDC	1	1	1	1
4559009	HARNESS, JUMPER	1	1	1	1
1679005	FLST. LIGHT FILTER-120/230V	1	1	1	1
6532027	COVER, BALLAST & HARNESS	1	1	1	1
6532039	KIT DISPLAY PANEL ASSEMBLY	1	1	1	1
6232132	LABEL, FRESHLY GROUND & BREWED	1			
6232060	LABEL, INSTRUCTION & CUP SIZE	1			
6272001	LABEL, CAUTION, HOT BEVERAGES	1			
6232513	LABEL, SANITATION	1	1		
6552016	LABEL, MENU, U.S./U.K.	1	1		
6232148	LABEL, INSTR. & CUP SIZE, UK		1		

THIS KIT CONTAINS THE FOLLOWING (CONTINUED)

PART NUMBER	DESCRIPTION	QTY PER KIT			
		6532035	6532037	6532040	6532042
6232194	LABEL, INSTR. & CUP SIZE, XTRA, GER			1	
6232142	LABEL, SANITATION, GERMAN			1	
6552032	LABEL, MENU, GERMAN			1	
6232257	LABEL, INSTRUCTION, FRANCE				1
6232143	LABEL, SANITATION, FRANCE				1
6532002	LABEL, MENU, FRANCE				1
1451097	SCREW, #8-32 X .31 LG. (SHORT BLACK)	6	8	8	8
4741050	SCREW, #8-32 X .50 LG. (LONG BLACK)	4	4	4	4

Overview of the modification:

The modification kit is being offered to add a backlit P.O.P. display to the machine.

Part I. Prepare the machine:

1. Turn off the power switch and unplug the machine from its power source.

Part II. Remove the following components (see figure 1) and retain:

1. Remove the cup mech. and canister assembly by loosening the four mounting bolts, unplugging the harness and removing the screws that attach the two tilt straps to the upper light bracket.
2. Remove the display panel assembly by removing the three thumbscrews from the side of the display panel.

CAUTION

After completing steps 3 thru 5 caution should be used as the door glass is retained only on the one side. Do not press on the glass from the front of the door.

3. Remove the display mount bracket from the hinge side of the door by removing four screws. Discard the display mount bracket
4. Remove the lower display panel mount assembly by removing four screws. Discard the lower display panel mount.
5. Unplug and remove the upper light bracket assembly. On international machines remove the wire and ballast guards.

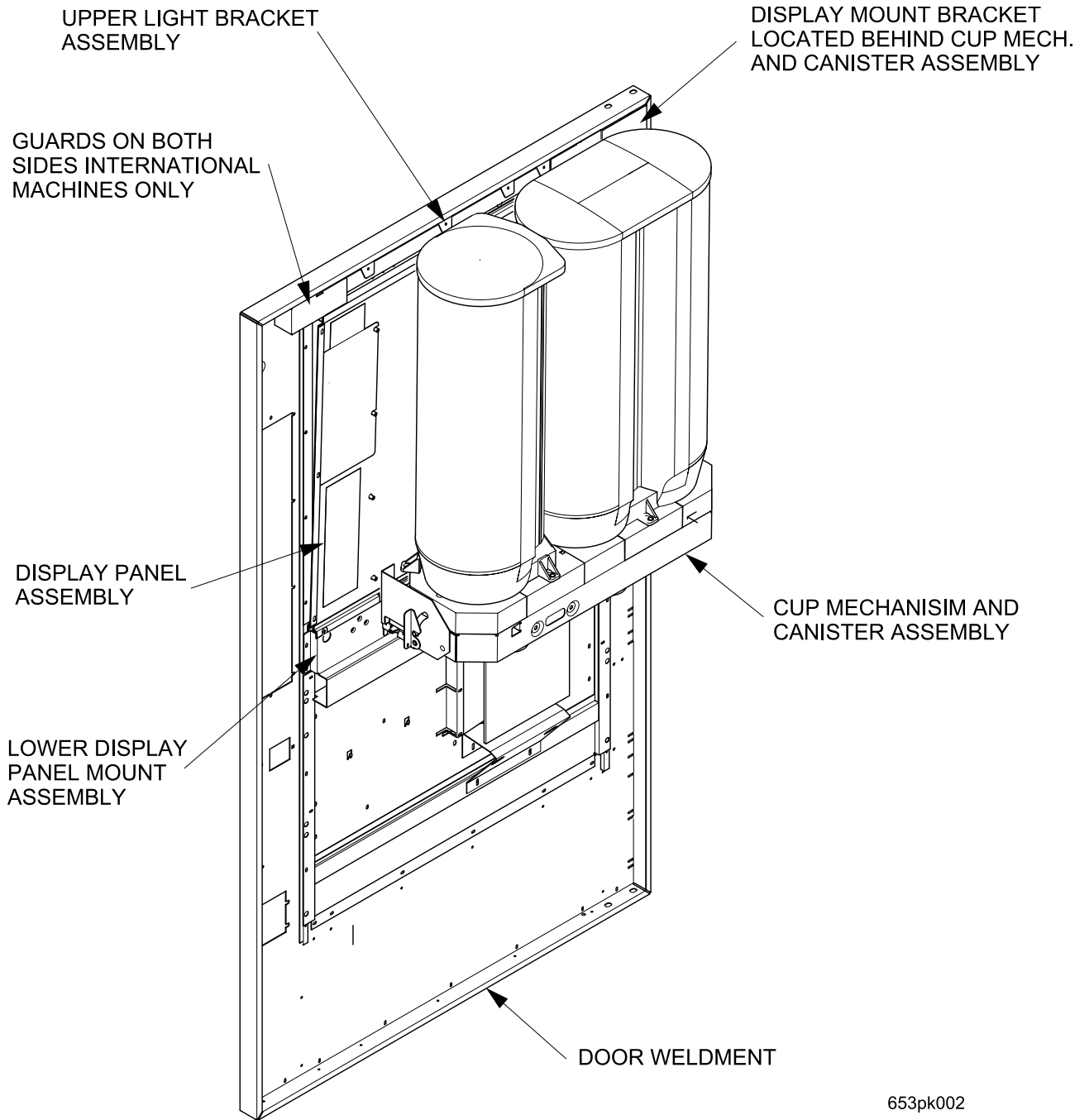

Figure 1

Part III. Sub-Assemble the following components:

1. Disassemble the upper light assembly and reassemble the removed components on the new upper light tube bracket (6532016) making sure to place the insulation disc (6532017) under the starter socket for grounding protection.
2. Attach labels to the front and back of the display panel assembly (6532039) as shown (see figure 2) (use the old display panel as a guide for locating the labels). Move all of the product selection inserts from the old display panel to the new display panel. Move the bean window filler to the new display if applicable. Discard the old display panel.

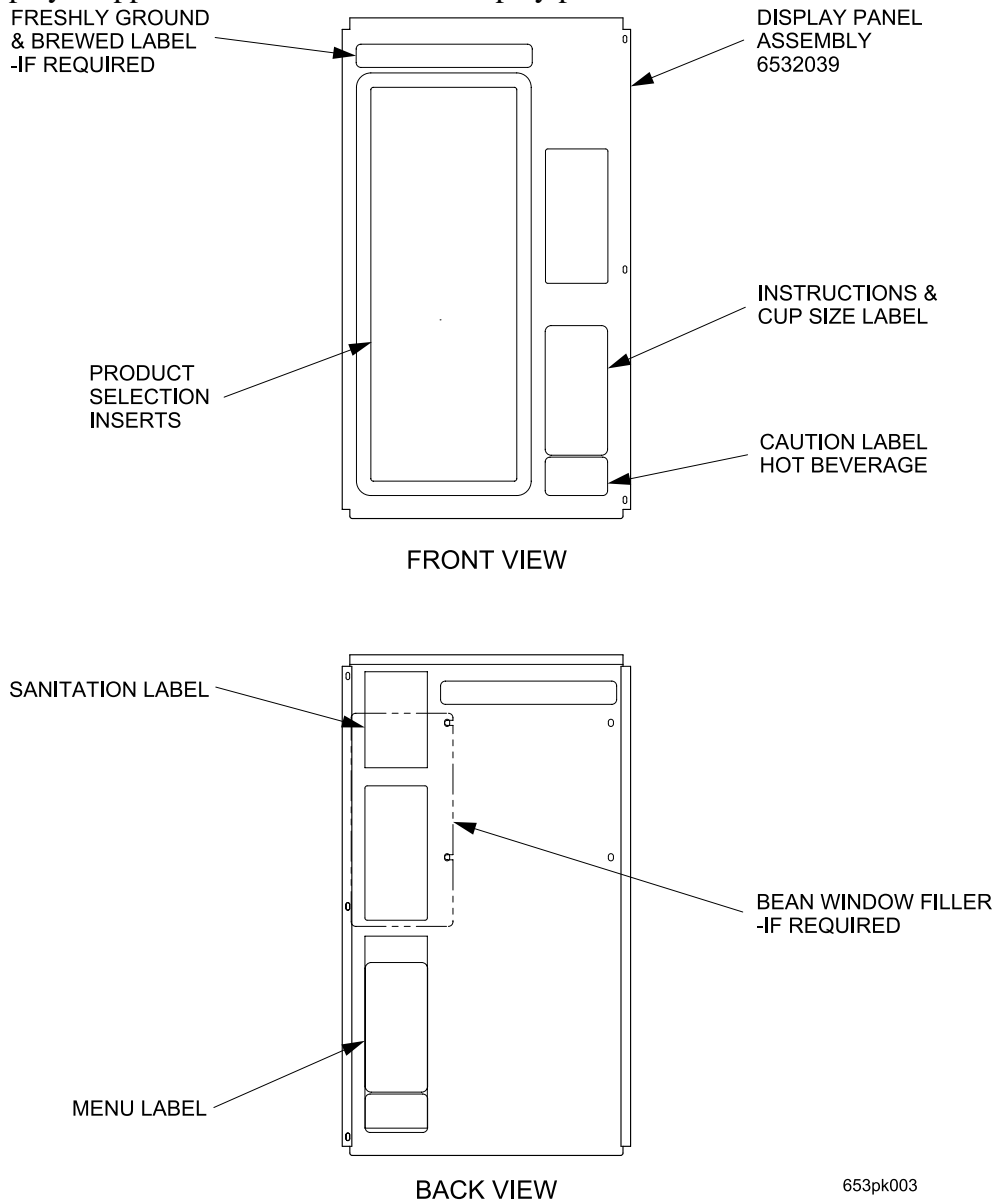

Figure 2

3. **ON INTERNATIONAL MACHINES ONLY:** Assemble upper light ballast to new bracket 6532060 using two (2) 1451097 short black screws.

Part IV. Installing the Backlit Display Kit (see figure 3):

1. Install the upper light assembly (sub-assembled in part III) making sure to shift it one slot (approx. 2") to the left (away from the door hinge) using existing hardware.

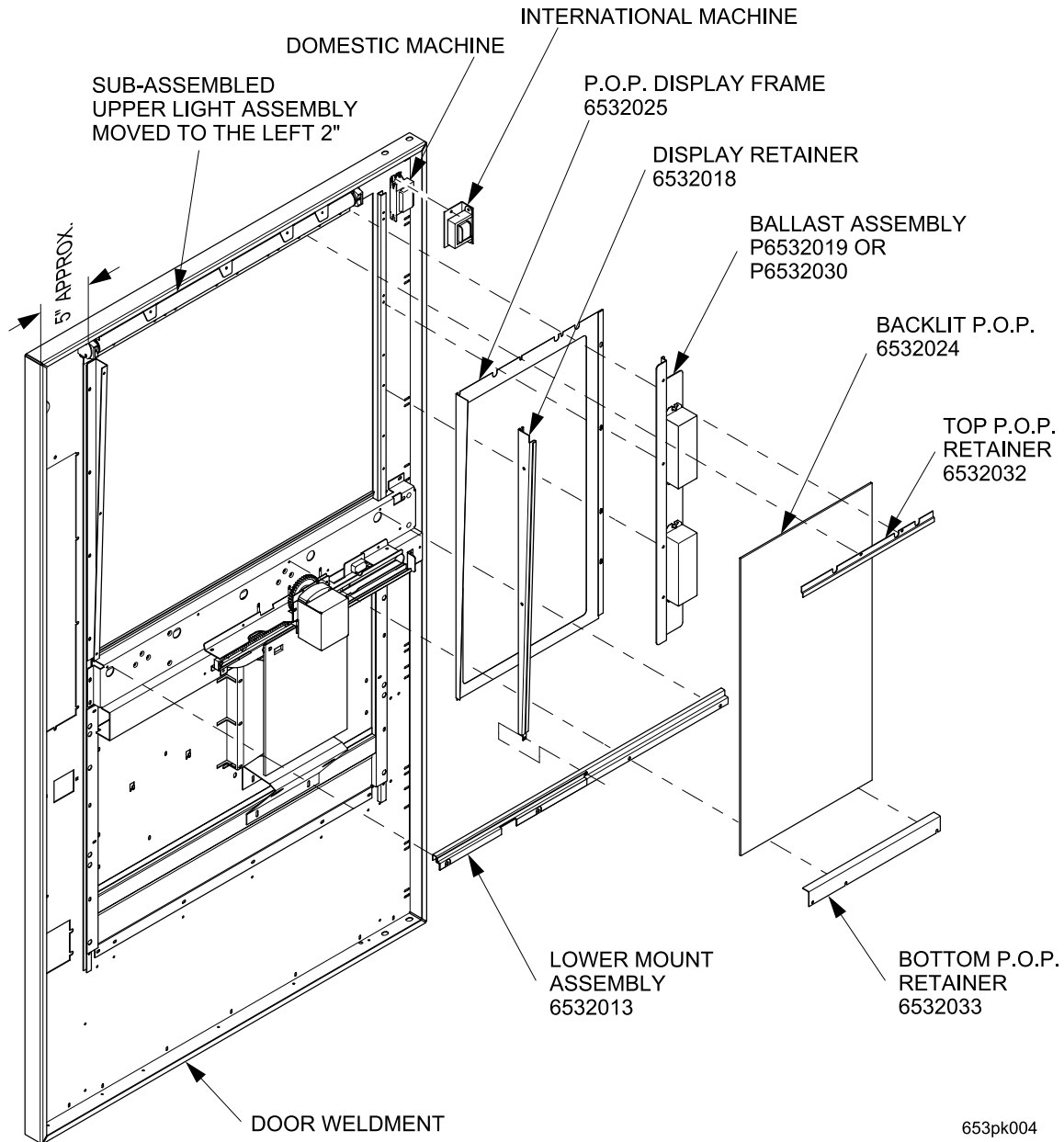

Figure 3

ON INTERNATIONAL MACHINES: Install the upper light ballast and bracket assembly from part III, step 3.

2. Loosely install the lower mount assembly (6532013) using four existing short black screws.
3. Position the P.O.P. display frame (6532025) capturing the lower flange in front of the lower mount assembly installed in step 2 and install the display retainer (6532018) using two existing short black screws.

4. Install the ballast assembly (P6532019 or P6532030) using the two middle mounting holes only by screwing through the slots in the P.O.P. display frame and into the door weldment with two long black screws.
5. Position the backlit P.O.P. (6532024) and retain by installing the top P.O.P. retainer (6532032) using two existing short black screws and bottom P.O.P. retainer (6532033) under two screws used to attach the lower mount assembly. Tighten the lower mount assembly screws.
6. Install the new display panel assembly (sub-assembled in part III) using three existing thumb-screws. (see figure 4)

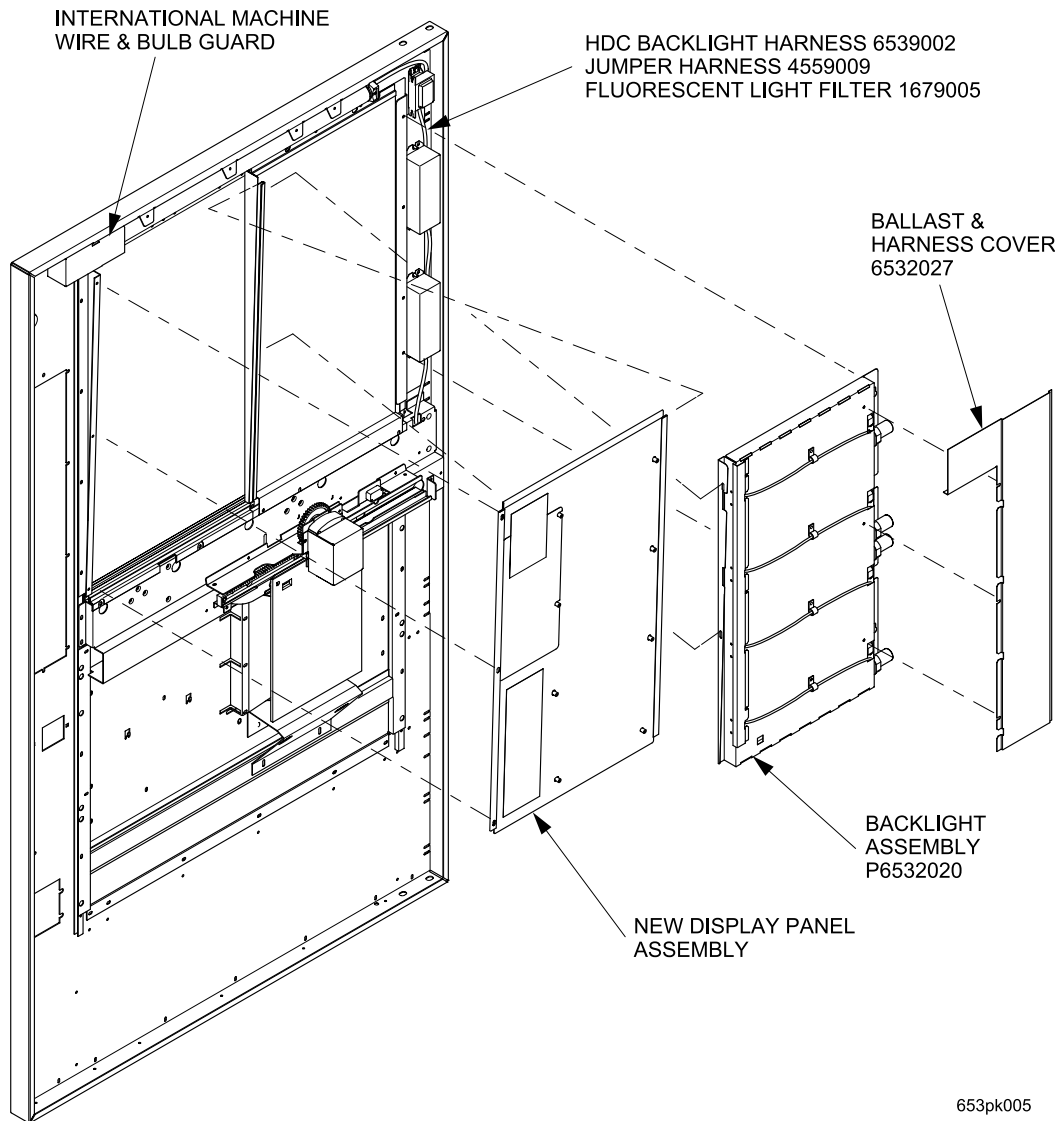

Figure 4

7. Install the backlight assembly (P6532020) by inserting onto pins in the display retainer and using two long black screws through the ballast assembly and into the door weldment.
8. Install the HDC backlight harness (6539002) to the four lamp harnesses and to the two ballasts with the end connector at the top.

-
9. Install the jumper harness (4559009) to the end of the door harness. Install the fluorescent light filter (1679005) to one end of the jumper harness and then to the backlight harness. Connect the other end of the jumper harness to the new upper light assembly. Reconnect the upper fluorescent light harness to the ballast and dress the wires inside the door flanges.
 10. Temporarily plug in machine to the power source and turn on the power switch. Check that all bulbs light up. Turn off the power switch and unplug the machine.

WARNING

Failure to disconnect machine from electrical supply could result in a shock hazard.

11. Install the ballast & harness cover (6532027) using three short black screws.
12. On international machines replace the wire and bulb end guard on the left side of the upper light assembly.

Part V. Reassemble (see figure 1):

1. Replace the cup mech. and canister assembly removed in part II, on to the four mounting bolts and tighten the four bolts. Replace the two tilt straps using existing screws. Plug in the cup mech. harness.

Part VI. Return the machine to service:

1. Restore power to the machine.
2. The modification procedure is complete.